

Overview

HPE ProLiant m710p Server Cartridge

HPE Moonshot System with the HPE ProLiant m710p server cartridge is designed to enhance the performance of Rich Application Streaming and Video Transcoding. The ProLiant m710p server cartridge has one Intel® Xeon® E3-1284L v4 four-core processor with Intel® Iris™ Pro P6300 graphics, 32GB of ECC protected memory, 10Gb Ethernet along with one M.2 flash storage module for local OS booting.

The HPE Moonshot System uses an innovative new architecture that results from one simple design tenet: to align purpose-built modules with the right workload to provide optimal results for your environment. Traditional servers rely on dedicated components, including management, networking, storage, power cords and cooling fans in a single chassis. In contrast, the Moonshot system shares these chassis components and is capable of supporting 45 servers cartridge per 4.3U chassis.

This gives you the ability to generate greater revenue from a smaller footprint while driving down your operational costs.

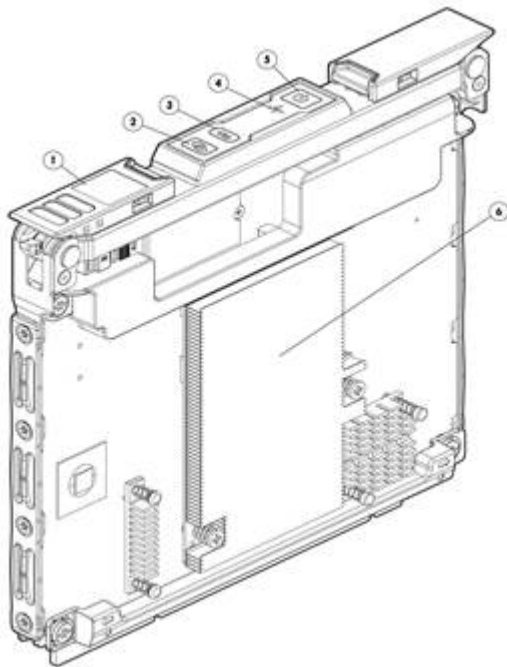

Front View:

1. QR Code label
2. Cartridge Link LED/button
3. Cartridge UID LED/button
4. Drive LED
5. Cartridge power LED/button
6. One (1) Intel® Xeon E3-1284Lv4™ Processor

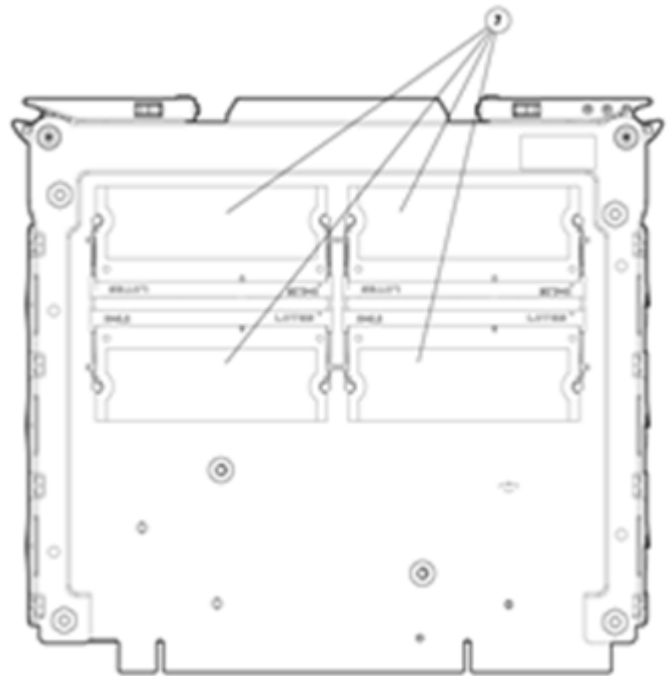

Rear View:

7. Four (4) DDR3 SODIMM memory slots

Standard Features

NOTE: For information on Hewlett Packard Enterprise Moonshot Chassis, Switch and Uplink Modules, please see the following:

Chassis:

HPE Moonshot 1500 Chassis Opt OS

<http://www8.hp.com/us/en/products/servers/moonshot/index.html>

Switch:

FastPATH

HPE Moonshot-45G Switch Module

<https://www.hpe.com/h20195/v2/GetHTML.aspx?docname=c04111070>

HPE Moonshot-180G Switch Module

<https://www.hpe.com/h20195/v2/GetHTML.aspx?docname=c04111290>

Comware

HPE Moonshot-45Gc Switch Module

<http://www8.hp.com/us/en/products/servers/moonshot/index.html>

HPE Moonshot-45XGc Switch Module

<https://www.hpe.com/h20195/v2/GetHtml.aspx?docname=c04384058>

Uplink:

HPE Moonshot-6SFP+ Uplink Module

<https://www.hpe.com/h20195/v2/GetHTML.aspx?docname=c04111292>

HPE Moonshot-16SFP+ Uplink Module

<https://www.hpe.com/h20195/v2/gethtml.aspx?docname=c04499458>

HPE Moonshot-4QSFP+ Uplink Module

<https://www.hpe.com/h20195/v2/GetHTML.aspx?docname=c04111291>

Processor Intel® Xeon® E3-1284L v4 (2.9-3.8GHz/4-core/6MB/47W)
Integrated Intel® Iris™ Pro P6300 graphics and 128MB of embedded DRAM

Cache Memory 6MB shared Level 3

Memory Protection ECC

Memory	Type	HPE 8GB (1x8GB) PC3L-12800 (DDR3-1600) SODIMM Low Voltage Memory
	DIMM Slots Available	Four (4) SODIMM Slots
	Maximum Configuration	32GB (4x8GB)

Network Controller Mellanox Connect-X3 Pro
Dual 10GbE NIC. Supports RDMA over Converged Ethernet (RoCE)

Storage Controller Integrated into the Intel® QM87 chipset

Standard Features

M.2 2280 solid state device	765479-B21	120GB
	765481-B21	240GB
	765483-B21	480GB
	827245-B21	960GB

NOTE: m710p cartridge may be purchased with zero M.2 storage (i.e. network/diskless boot).

Interfaces

Cartridge Link LED/button
Cartridge UID LED/button
Drive LED
Cartridge health LED
HDMI 1.4b compliant connector for external monitor
Micro-USB 2.0 connector

NOTE: HDMI and Micro-USB connectors are for diagnostic usage only and may require removal of any adjacent cartridge.

NOTE: To connect a standard USB device to the cartridge, connect a USB on-the-go adapter to the cartridge Micro-USB connector, and then connect the USB device to the adapter.

Industry Standard Compliance

PXE Support
PCIe 3.0
iSCSI Boot (with supported operating systems)

Operating Systems and Virtualization Software Support for ProLiant Servers

Microsoft Windows Server 2012 / 2012 R2, Windows 2008 R2, Client OS
Windows 7, 8.1
SUSE Linux Enterprise Server (SLES) 11.4, 12
Canonical Ubuntu 15.04, 14.04.3 LTS
CentOS 6.7, 7.2

NOTE: Only 64-bit versions of these operating systems are supported.

NOTE: For more information on Hewlett Packard Enterprise's Certified and Supported ProLiant Servers for OS and Virtualization Software and latest listing of software drivers available for your server including how to purchase from Hewlett Packard Enterprise, please visit our OS Support Site at:

<http://www.hp.com/go/ossupport> and our driver download page:
<http://www.hp.com/go/servers/Moonshot/download>

Form Factor

HPE ProLiant m710p Server Cartridge is a server cartridge that plugs into the HPE Moonshot 1500 Chassis.

Security

Serial interface control
Power switch security
Administrator's password

Standard Features

Warranty

This product is covered by a global limited warranty and supported by Hewlett Packard Enterprise Services and a worldwide network of Hewlett Packard Enterprise Authorized Channel Partners resellers. Hardware diagnostic support and repair is available for three years from date of purchase. Support for software and initial setup is available for 90 days from date of purchase. Enhancements to warranty services are available through HPE Care Pack services or customized service agreements. Hard drives have either a one year or three year warranty; refer to the specific hard drive QuickSpecs for details.

NOTE Server Cartridge Warranty includes 3-Year Parts, 0-Year Labor, 0-Year Onsite support. Additional information regarding worldwide limited warranty and technical support is available at:

<http://h18004.www1.hp.com/products/servers/platforms/warranty/index.html>

Optional Features

HPE Insight Cluster Management Utility (CMU)

HPE Insight Cluster Management Utility (CMU) is an Hewlett Packard Enterprise-licensed and Hewlett Packard Enterprise-supported suite of tools that are used to manage large-scale systems. Insight CMU includes software for the centralized provisioning, management and monitoring of nodes. Insight CMU makes the administration of clusters more user friendly, efficient, and error free than if they were being managed by scripts, or on a node-by-node basis. For more information on Hewlett Packard Enterprise Insight Cluster Management Utility, please contact your sales representative or go to: <http://www.hp.com/go/cmu>

Factory Express Portfolio for Servers and Storage

HPE Factory Express offers configuration, customization, integration and deployment services for Hewlett Packard Enterprise servers and storage products. Customers can choose how their factory solutions are built, tested, integrated, shipped and deployed.

Factory Express offers service packages for simple configuration, racking, installation, complex configuration and design services as well as individual factory services, such as asset tagging, and custom packaging. Hewlett Packard Enterprise products supported through Factory Express include a wide array of servers and storage: HPE Moonshot, HPE Integrity, HPE ProLiant, HPE ProLiant Server Blades, and HPE BladeSystem, HPE 9000 servers as well as the MSAxxxx, VA7xxx, EVA, XP, rackable tape libraries and configurable network switches.

For more information on Factory Express services for your specific server model please contact your sales representative or go to: <http://www.hp.com/go/factory-express>.

Service and Support

Service and Support To see recommended HPE Care Pack Services for your HPE product
(4 and 5 year Service offerings are also available)
See HPE Moonshot 1500 Chassis Opt OS Quick Specs.
<http://www8.hp.com/us/en/products/servers/moonshot/index.html>

For more information

To learn more on HPE Moonshot System, please contact your Hewlett Packard Enterprise sales representative.

Configuration Information - Factory Integrated Models

NOTE: This section lists some of the steps required to configure a Factory Integrated Model. To ensure only valid configurations are ordered, Hewlett Packard Enterprise recommends the use of an Hewlett Packard Enterprise approved configurator. Contact your local sales representative for information on configurable product offerings and requirements

NOTE: If you want to configure the HPE Moonshot 1500 Chassis Opt OS with cartridges, proceed to the HPE Moonshot 1500 Chassis Opt OS Quick Specs

<http://www8.hp.com/us/en/products/servers/moonshot/index.html>

NOTE: If you want to configure a cartridge only, proceed to Step 1

Step 1: Base Configuration (Choose upgrade kit)

HPE Moonshot Server Upgrade Kit	HPE Moonshot Server Multipack	814659-B21
	NOTE: up to 15 cartridges of any kind fit in this multipack	
	NOTE: Mixed Cartridge configuration is supported	

Step 2: Pick Moonshot Server

HPE Moonshot Server	HPE ProLiant m710p Server Cartridge	808915-B21
	NOTE: Mixed Cartridge configuration is supported	
	NOTE: Each Moonshot server comes preconfigured with four 8 GB SODIMM pre-installed. This is the only memory configuration available on this server.	
	NOTE: Each Moonshot cartridge is pre-configured with a single Intel® Xeon® E3-1284L v4 (x86-64) processor running at 2.9-3.8GHz. This processor is four-core and contains 6MB of shared L3 cache. The same processor package also contains an Integrated Intel® Iris™ Pro P6300 graphics controller and 128MB of embedded DRAM.	

Step 3: Configure Moonshot Servers (Choose appropriate Option)

HPE Solid State	Optional Factory Integration Options (FIO)	
	NOTE: Additional options are not configurable for server upgrade kits.	
	NOTE: Must order identical quantity as configured Moonshot server	
	HPE Moonshot 120GB M.2 2280 Solid State Device	765479-B21
	HPE Moonshot 240GB M.2 2280 Solid State Device	765481-B21
	HPE Moonshot 480GB M.2 2280 Solid State Device	765483-B21
	HPE Moonshot 960GB M.2 2280 Solid State Device	827245-B21

Step 4: To Select a different cartridge see details:

<http://www8.hp.com/us/en/products/servers/moonshot/index.html>

Technical Specifications

Server Cartridge	HPE Moonshot m710p Server Cartridge Dimensions (H x W x D)	6.57 x 7.23 x 0.78in (16.71 x 18.37 x 1.98cm)
	Typical Power	58.0W
	Max Power	82.9W
System Inlet Temperature	Operating	50° to 95° F (10° to 35° C) at sea level with an altitude derating of 1.8°F per every 1000 ft (1.0°C per every 304.8 m) above sea level to a maximum of 10,000 ft (3048 m), no direct sustained sunlight. Maximum rate of change is 18°F/hr (10°C/hr). The upper limit may be limited by the type and number of options installed. System performance may be reduced if operating with a fan fault or above 86°F (30°C).
	Non-operating	-22° to 140° F (-30° to 60° C) Maximum rate of change is 36°F/hr (20°C/hr).
Relative Humidity (non-condensing)	Operating	10 to 90% relative humidity (Rh), 28°C (82.4°F) maximum wet bulb temperature, non-condensing.
	Non-operating	5 to 95% relative humidity (Rh), 38.7°C (101.7°F) maximum wet bulb temperature, non-condensing.
Altitude	Operating	10,000 ft (3048 m). This value may be limited by the type and number of options installed. Maximum allowable altitude change rate is 1500 ft/min (457 m/min).
	Non-operating	30,000 ft (9144 m). Maximum allowable altitude change rate is 1500 ft/min (457 m/min).
Acoustic Noise	Listed are the declared A-Weighted sound power levels (LWAd) and declared average bystander position A-Weighted sound pressure levels (LpAm) when the product is operating in a 23°C ambient environment. Noise emissions were measured in accordance with ISO 7779 (ECMA 74) and declared in accordance with ISO 9296 (ECMA 109).	
	Idle	
	L WAd	7.1 Bels
	L pAm	54 dB
	Operating	
	L WAd	7.3 Bels
	L pAm	57 dB

Technical Specifications

Environment-friendly Products and Approach

End-of-life Management and Recycling

Hewlett Packard Enterprise offers end-of-life Hewlett Packard Enterprise product return, trade-in, and recycling programs in many geographic areas. For trade-in information, please go to: <http://www.hp.com/go/green>. To recycle your product, please go to: <http://www.hp.com/go/green> or contact your nearest Hewlett Packard Enterprise sales office. Products returned to Hewlett Packard Enterprise will be recycled, recovered or disposed of in a responsible manner.

The EU WEEE directive (2002/95/EC) requires manufacturers to provide treatment information for each product type for use by treatment facilities. This information (product disassembly instructions) is posted on the Hewlett Packard Enterprise web site at: <http://www.hp.com/go/green>. These instructions may be used by recyclers and other WEEE treatment facilities as well as HPE OEM customers who integrate and re-sell Hewlett Packard Enterprise equipment.

Summary of Changes

Date	Version History	Action	Description of Change
28-Oct-2016	From version 3 to 4	Updated	Update QuickSpecs for Rebranding
9-Oct-2015	From version 2 to 3	Updated	Update the Standard Features section
28-Sept-2015	From version 1 to 2	Updated	Update all the sections throughout the QS
17-Aug-2015	Version 1	Created	Create QS for HPE ProLiant m710p Server Cartridge



© Copyright 2016 Hewlett Packard Enterprise Development LP. The information contained herein is subject to change without notice. The only warranties for Hewlett Packard Enterprise products and services are set forth in the express warranty statements accompanying such products and services. Nothing herein should be construed as constituting an additional warranty. Hewlett Packard Enterprise shall not be liable for technical or editorial errors or omissions contained herein.

Microsoft and Windows NT are US registered trademarks of Microsoft Corporation. Intel, the Intel logo, Xeon and Xeon Inside are trademarks of Intel Corporation in the U.S. and other countries.

For hard drives, 1GB = 1 billion bytes. Actual formatted capacity is less.

c04760473 - 15352 - Worldwide - V4 - 28-October-2016

